

DESIGN NOTES

LTC1646: Power Supply Isolation Controller Simplifies Hot Swapping the CompactPCI Bus for 5V-/3.3V-Only Applications

Design Note 253

Andy Gardner

Although $\pm 12\text{V}$ supplies are provided on the CompactPCI™ backplanes, many plug-in boards only require 5V and 3.3V. The LTC®1646 is the ideal power supply isolation controller for these applications.

The LTC1646 Hot Swap™ controller is designed to meet the power supply isolation requirements found in the CompactPCI hot swap specification PICMG™ 2.1 for plug-in boards requiring 5V and/or 3.3V supplies. The chip will turn a board's supply voltages on and off in a controlled manner, allowing the card to be safely inserted or removed without causing glitches on the power supplies and causing other boards in the system to reset. It also protects against short circuits, precharges the bus I/O connector

pins during insertion and extraction and reports on the state of the supply voltages via the HEALTHY# signal.

LTC1646 Feature Summary

The LTC1646 features can be summarized as follows:

- Controls 5V and/or 3.3V CompactPCI supplies.
- Dual level, programmable circuit breakers: this feature is enabled after power-up is complete. If either supply exceeds current limit for more than 20 μs , the circuit breaker will trip and the chip latches off. In the event that

LT, LTC and LT are registered trademarks of Linear Technology Corporation. Hot Swap is a trademark of Linear Technology Corporation. CompactPCI and PICMG are trademarks of PCI Industrial Computer Manufacturers Group.

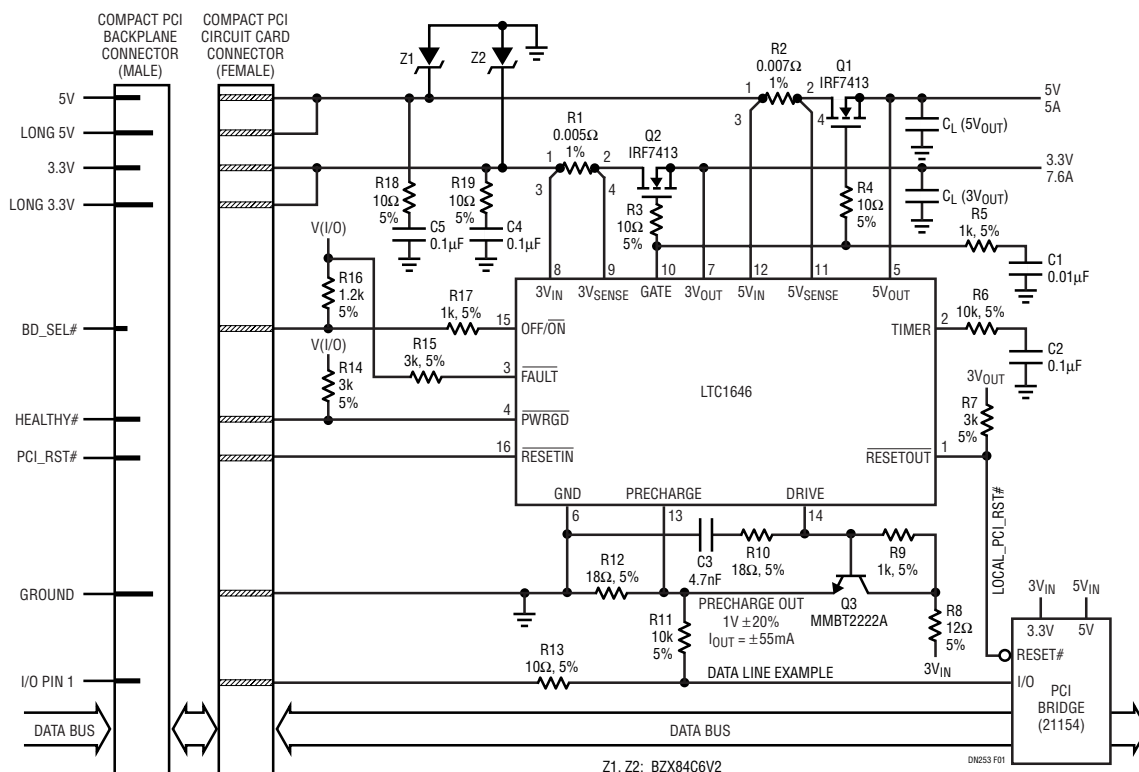

Figure 1. CompactPCI Application with Only 3.3V and 5V Supplies

either supply exceeds three times the set current limit, all supplies are disabled and the chip latches off without delay.

- Current limited power-up: the supplies are allowed to power up in current limit. This allows the chip to power up boards with widely varying capacitive loads without tripping the circuit breaker. The maximum allowable power-up time is programmable using the TIMER pin and an external capacitor.
- Programmable foldback current limit: a programmable analog current limit with a value that depends on the output voltage. If the output is shorted to ground during the power-up cycle, the current limit drops to keep power dissipation and supply glitches to a minimum.
- Precharge output: on-chip reference and amplifier provide 1V for biasing bus I/O connector pins during card insertion and extraction.
- BD_SEL#, HEALTHY#, PCI_RST# and LOCAL_PCI_RST# signals are supported.
- Space saving 16-pin SSOP package.

Typical Application

Figure 1 shows a typical application using the LTC1646.

The main 3.3V and 5V inputs to the LTC1646 come from the medium-length power pins. The long 3.3V and 5V connector pins are shorted to the medium length 5V and 3.3V connector pins on the plug-in card and provide early power for the LTC1646's precharge circuitry, the V(I/O) pull-up resistors and the PCI bridge chip. The BD_SEL# signal is connected to the OFF/ON pin while the PWRGD pin is connected to the HEALTHY# signal. The HEALTHY# signal is combined on chip with the PCI_RST# signal to generate the LOCAL_PCI_RST# signal which is available at the RESETOUT pin.

The power supplies are controlled by placing external N-channel pass transistors Q1 and Q2 in the 3.3V and 5V power paths. Resistors R1 and R2 sense overcurrent conditions, and R5 and C1 provide current control-loop compensation. Resistors R3 and R4 prevent high frequency oscillations in Q1 and Q2.

Power-Up Sequence

Figure 2 shows a typical power-up sequence.

Data Sheet Download

<http://www.linear-tech.com/go/dnLTC1646>

When the CompactPCI card is inserted, the long 5V, 3.3V and GND connector pins make contact first. The LTC1646's precharge circuit biases the bus I/O pins to 1V during this stage of the insertion. The 5V and 3.3V medium length pins make contact during the next stage of the insertion, but the slot power is disabled as long as the OFF/ON pin is pulled high by the 1.2k pull-up resistor to V(I/O). During the final stage of the board insertion, the BD_SEL# short connector pin makes contact and the OFF/ON pin can be pulled low. This enables the pass transistor to turn on and a 5µA current source is connected to the TIMER pin. Each supply is then allowed to power up at the rate $dV/dt = 13\mu A/C1$ or as determined by the current limit and the load capacitance, whichever is slower. Current-limit faults are ignored while the TIMER pin voltage is less than 1.25V. Once both supplies are within tolerance, the HEALTHY# signal is pulled low and the LOCAL_PCI_RST# signal goes high.

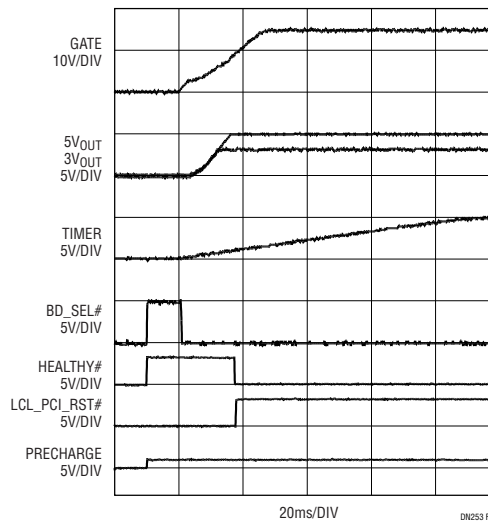

Figure 2. Normal Power-Up Sequence

Conclusion

Using the LTC1646, a CompactPCI board can be made hot swappable so the system power can remain uninterrupted while the board is being inserted or removed. With the LTC1646, safe hot swapping becomes as easy as hooking up an IC, a couple of power FETs and a handful of resistors and capacitors.

For literature on our Hot Swap Controllers, call **1-800-4-LINEAR**. For applications help, call (408) 432-1900, Ext. 2453